

NOTE: COUPLING CAN BE USED AT WIDTH SHOWN OR CUT DOWN WITH CLAMPS MOVED TO INSIDE GROOVES

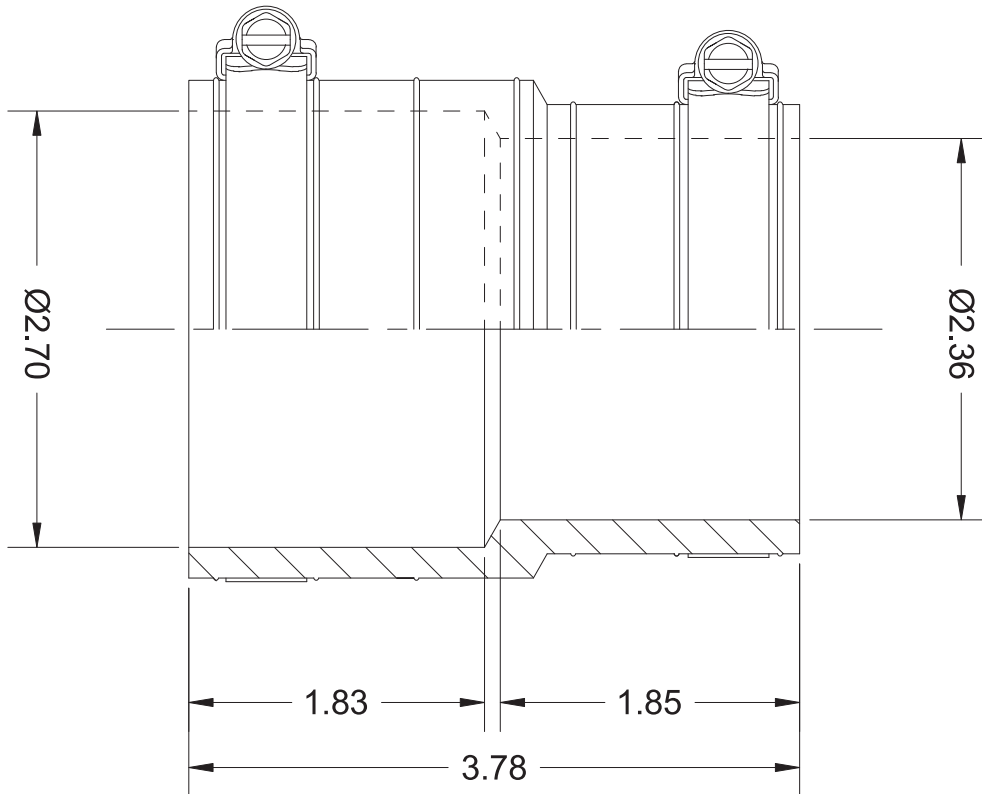

A GPK PRODUCTS Company

MATERIAL LIST

QTY	ITEM	P/N
1	COUPLING	159-22
2	CLAMP	SSHC-44

FOR REFERENCE ONLY DIMENSIONS SUBJECT TO CHANGE

TITLE

FLEXIBLE COUPLING
2" SOCKET TO PIPE

1-800-428-5309 FARGO, ND

DATE 07-21-09

SCALE NONE

PART NO. 159-22